

AC-12 MODEL

GALVANNEAL ROUND SINGLE BLADE DAMPER FOR DUCT INSTALLATION, MANUAL GAUGE OF 3/8"(DIAM 6" TO 14") AND 1/2" (DIAM 16" TO 24")

- Useful in HVAC systems in which air flows are managed at low pressure and medium and low velocity.
- Manual powered, it allows to adjust the blade circular movement, from fully open or closed, to position that suits the operation of air distribution system.
- Available diameters: 6", 8", 10", 12", 14", 16", 18" y 20".

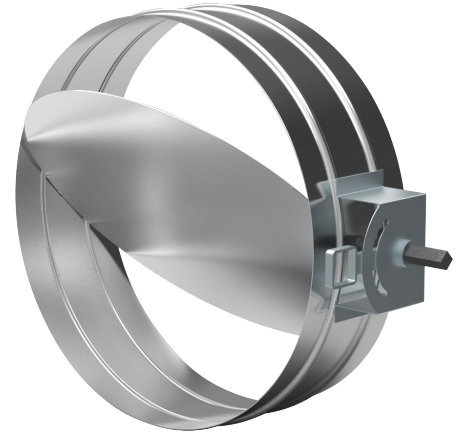

CONSTRUCTION: Galvanneal sheet.

FINISH: Galvanneal.

PERFORMANCE: The round damper allows to moderate the air flow supply trough the duct, facilitating the balancing of the distribution system because allows to handle the required air volume constantly trough the distribution duct.

Dimensional Data

